

Accessories.

EXTRACTION DEVICE ROTARY VALVE TYPES

AZV

For all types which are available in quick cleaning execution

FXS

Device on rails for quick, precise extractions of the rotor without lifting
Swing-open extraction device for the optimal access (see hygienic components)

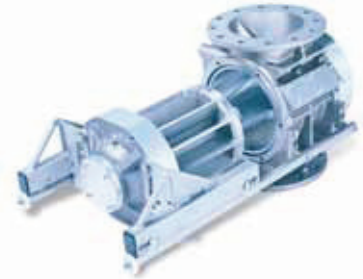

COPERION ROTORCONVEYOR' RCG

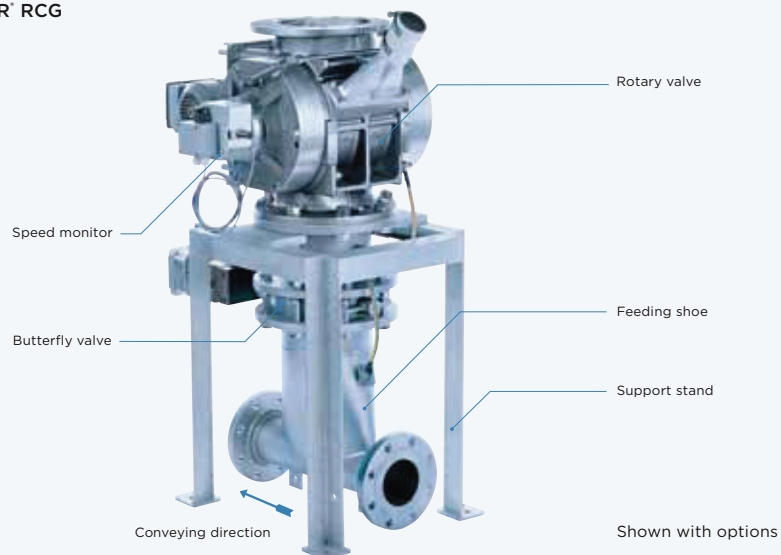

HEATED VALVE

- _ For heating the rotary valve at product temperatures higher than 120°C
- _ Heated with steam or circulated thermo-oil
- _ Minimizes gas leakage

SPEED MONITOR

- _ For sensing valve operating and speed monitoring



OPTIONS AND ACCESSORIES FOR ROTARY VALVES | ACCESSORIES

LEAKAGE GAS COLLECTOR

- _ Compact design for effective venting of the leakage gas for powder rotary valves
- _ Allows high conveying capacity even with long silo outlet gravity pipes or reduced inlet cross-section
- _ Available for valve types ZRD, ZXD, ZXQ, ZAQ and in two-part execution for ZKD

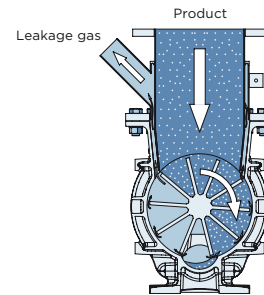

FEEDING STATION FOR DILUTE PHASE CONVEYING FFZ

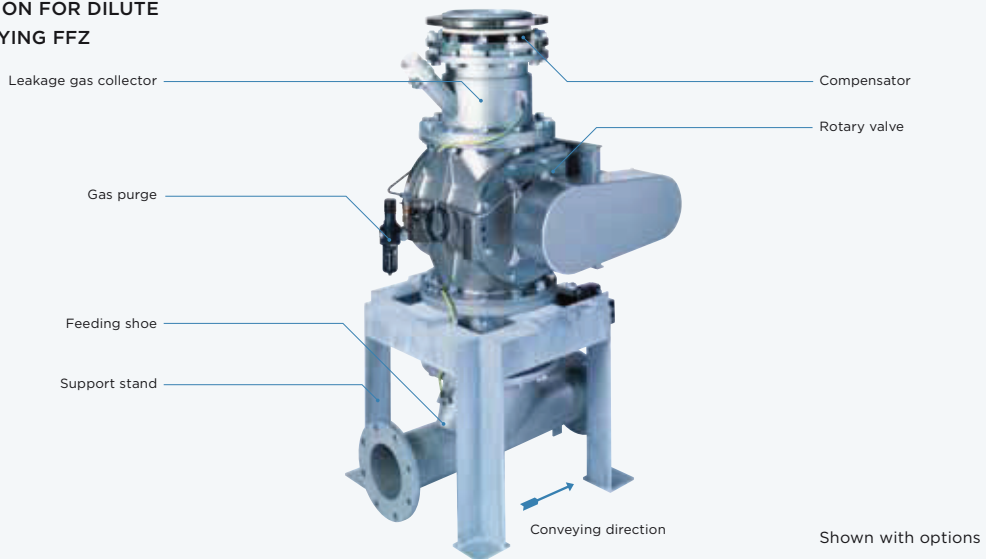

DENSE PHASE CONVEYING

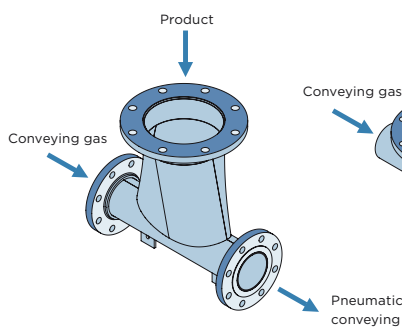

DILUTE PHASE CONVEYING

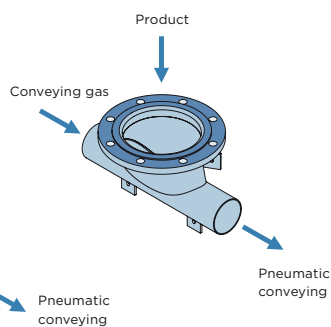

FEEDING SHOE FOR DILUTE PHASE CONVEYING STATION

- _ Guarantees optimal feed of bulk solids into the conveying pipe
- _ Pressure range up to 1.5 bar/3.5 bar
- _ Material of construction: stainless steel
- _ Available for all valve types
- _ Different connecting nominal diameter are available per size
- _ Optional connecting flange at conveying pipe
- _ Connecting flanges drilled according to DIN PN 10 or ANSI 150 lbs